

G2PA

Bent Axis Piston Pump



G2PA Pumps have the following advantages ;

- Compact Design,
- Economical Conception,
- High Power Density,
- High Overall Efficiency,
- High Rotating Speeds,
- High Output Pressure,
- 350 bar Cont. Work. Pressure,
- 400 bar Peak Pressure,
- From 12cc to 108cc,
- Reduced Noise Level,
- Increased Reliability,
- No Drain Line Necessary,
- Smaller Installation Dimensions,
- One Piece Pistons with Piston Rings,
- Special Inlet Fittings & Accessories,
- Simple Change of Direction of Rotation

Other Advantages of G2PA

New frame sizes to meet market requirements.

Optional by-pass valve.

For use in mobile & industrial and stationary applications areas.

The pump drive shaft bearings are designed to give the service life expected in these areas of operation.

Interchangeable with other bent axis pumps.

40° bent axis design giving high power, small overall dimensions, optimum efficiency and economic design. Flange and shaft designed for direct mounting on truck gearbox PTO's. The fixed displacement bent axis pumps generates a hydraulic fluid flow. It is designed for use in trucks, commercial vehicles and all stationary hydraulic applications. The G2PA is a fixed pump with rotary group in bent-axis design open circuits. Flow is proportional to drive speed and displacement.

For axial piston units with bent-axis design, the Pistons are arranged diagonally with respect to the drive shaft. The pump covers the whole displacement range 12 to 108 cm³/rev. The pump has been developed with modern styling and design to satisfy market demand as to designed new generation plate and pistons with give high flow performance, high pressures with high efficiency and very small dimensions.

The pump is available both to DIN and SAE world standards and can be mounted either directly at the gear box or via a drive shaft. If necessary it can also be augmented with a by-pass valve. Other brand bent axis pumps compatible and interchangeable with G2PA bent axis pumps. Refer to the data sheet and order confirmation for the technical data, operating conditions and operating limits of the bent axis piston pumps.

Contents

- Ordering Code of G2PA Pumps 4
- Technical Data I..... 5
- Technical Data II..... 6
- Performance 7

- Dimensions Size;
- G2PA 12 cc 8
- G2PA 18 cc 9
- G2PA 25 cc 10
- G2PA 32 cc 11
- G2PA 40 cc 12
- G2PA 50 cc 13
- G2PA 56 cc 14
- G2PA 63 cc 15
- G2PA 80 cc 16
- G2PA 108 cc 17

- Changing the Direction of Rotation 18
- Inlet Fittings, Accessories 19
- Installation & User Guide 20
- Complete Product Range 21
- Production, Contact 22

Ordering Code of G2PA Pumps

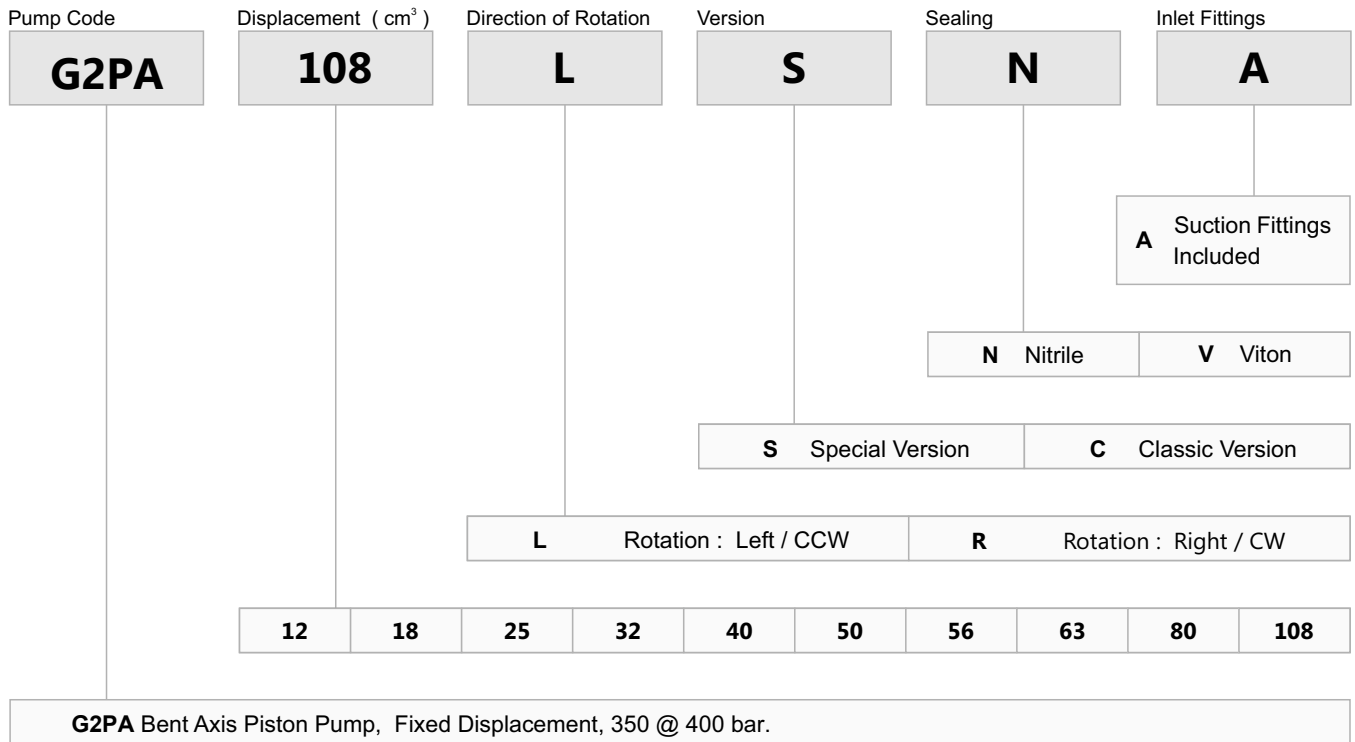

Classic Version ; Default design
Special Version ; Special for dealers

Formulas			
Pump Output Flow	GPM	$GPM = (Speed (rpm) \times disp. (cu. in.)) / 231$	$GPM = (n \times d) / 231$
Pump Input Horsepower	HP	$HP = GPM \times Pressure (psi) / 1714 \times Efficiency$	$HP = (Q \times P) / 1714 \times E$
Pump Efficiency	E	Overall Efficiency = Output HP / Input HP	$E_{overall} = HP_{out} / HP_{in} \times 100$
		Overall Efficiency = Volumetric Eff. \times Mechanical Eff.	$E_{overall} = Eff_{Vol.} \times Eff_{Mech.}$
Pump Volumetric Efficiency	E	Volumetric Efficiency = Actual Flow Rate Output (GPM) / Theoretical Flow Rate Output (GPM) \times 100	$Eff_{Vol.} = Q_{Act.} / Q_{Theo.} \times 100$
Pump Mechanical Efficiency	E	Mechanical Efficiency = Theoretical Torque to Drive / Actual Torque to Drive \times 100	$Eff_{Mech} = T_{Theo.} / T_{Act.} \times 100$
Pump Displacement	CIPR	$Displmnt (In.3 / rev.) = Flow Rate (GPM) \times 231 / Pump RPM$	$CIPR = GPM \times 231 / RPM$
Pump Torque	T	Torque = Horsepower \times 63025 / RPM	$T = 63025 \times HP / RPM$
		Torque = Pressure (PSIG) \times Pump Displacement (CIPR) / 2 π	$T = P \times CIPR / 6.28$

- Horsepower for driving a pump** : For every 1 hp of drive, the equivalent of 1 gpm @ 1500 psi can be produced.
- Horsepower for idling a pump** : To idle a pump when it is unloaded will require about 5% of it's full rated power
- Wattage for heating hydraulic oil** : Each watt will raise the temperature of 1 gallon of oil by 1° F. per hour.
- Flow velocity in hydraulic lines** : Pump suction lines 2 to 4 feet per second, pressure lines up to 500 psi - 10 to 15 ft./sec., pressure lines 500 to 3000 psi - 15 to 20 ft./sec.; all oil lines in air-over-oil systems; 4 ft./sec.

		12	18	25	32	40	50	56	63	80	108
Displacement	cc	12,00	18,00	25,00	32,00	40,20	50,00	56,40	63,00	80,00	108,4
Theoretical oil flow l/min at pump speed	1000 rpm	12,00	18,00	25,00	32,00	40,20	50,00	56,40	63,00	80,00	108,4
	1500 rpm	18,00	27,00	37,50	48,00	60,30	75,00	84,60	94,50	120,0	162,6
Maximum Pump Speed											
- Continuous	rpm	2300	2300	2300	2250	1900	1900	1900	1900	1700	1700
- Limited	rpm	3100	2900	2700	2700	2500	2500	2300	2300	2100	1900
Max. Continuous Pressure	bar	350	350	350	350	350	350	350	350	350	350
Max. Intermit. Peak Pressure	bar	400	400	400	400	400	400	400	400	400	400
Max. Torque at 350 bar	Nm	71	105	146	190	240	292	330	360	460	620
Weight											
- Without inlet fitting	kg	9,00	9,00	9,50	10,50	10,50	11,00	11,50	11,50	15,00	15,50
- With inlet fitting	kg	9,40	9,40	9,90	10,90	10,90	11,40	11,90	11,90	15,40	15,90
Overhang Torque											
- Without inlet fitting	N.m	8,70	8,75	8,82	11,00	11,12	11,72	11,79	11,82	17,80	17,92
- With inlet fitting	N.m	9,15	9,19	9,23	11,52	11,40	12,20	12,24	12,28	18,33	18,45
Rotation		CW,CCW	CW,CCW	CW,CCW	CW,CCW	CW,CCW	CW,CCW	CW,CCW	CW,CCW	CW,CCW	CW,CCW
Fluid		Mineral Based Hydraulic Oils									
Inlet & Outlet		3/4"	3/4"	3/4"	3/4"	3/4"	3/4"	3/4"	3/4"	1"	1"

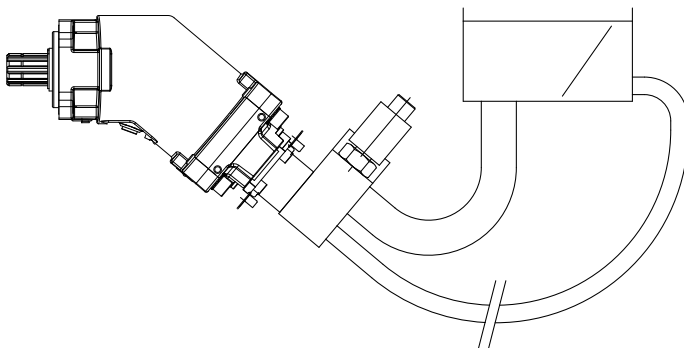

Overhang torque of G2PA pumps

		12	18	25	32	40	50	56	63	80	108
weight	without inlet fitting kg	12,81	12,82	12,89	14,06	14,70	14,80	14,84	14,86	18,42	18,50
	with inlet fitting 2" kg	13,23	13,33	13,37	15,12	15,17	15,24	15,28	15,30	18,95	19,01
torque	without inlet fitting N.m	16,33	16,38	16,42	19,14	18,97	20,07	20,10	20,11	27,18	27,30
	with inlet fitting 2" N.m	16,92	16,94	17,01	19,61	19,58	20,68	20,70	20,72	27,81	27,95

Efficiency Curves (1000 rpm)

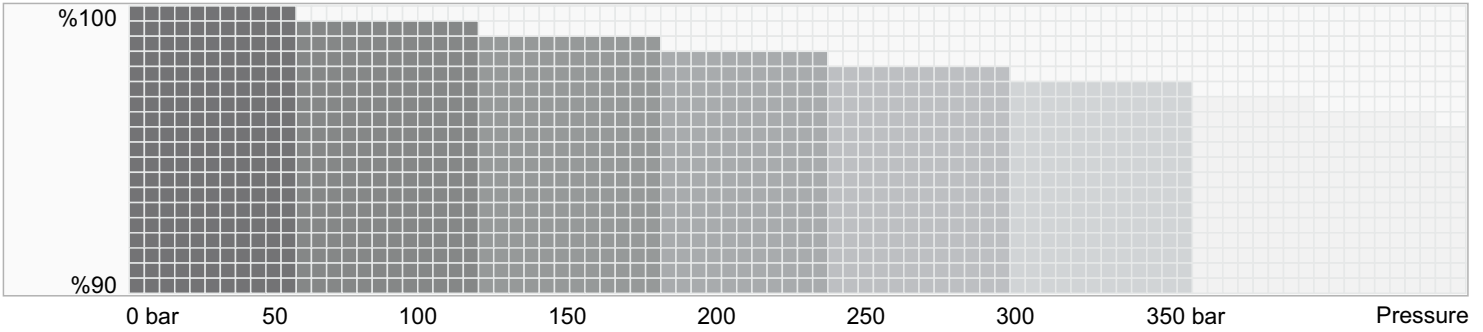

Torque with Pump Output Pressure

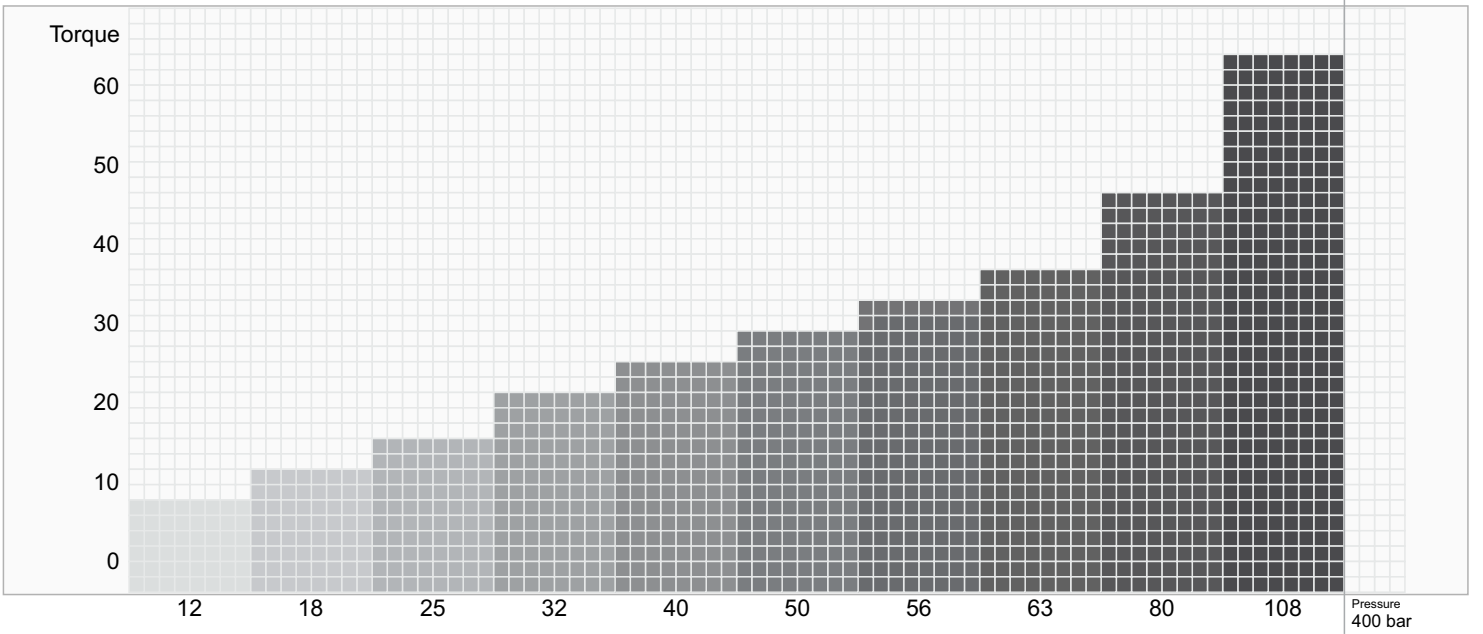

Flow with Pump Speed

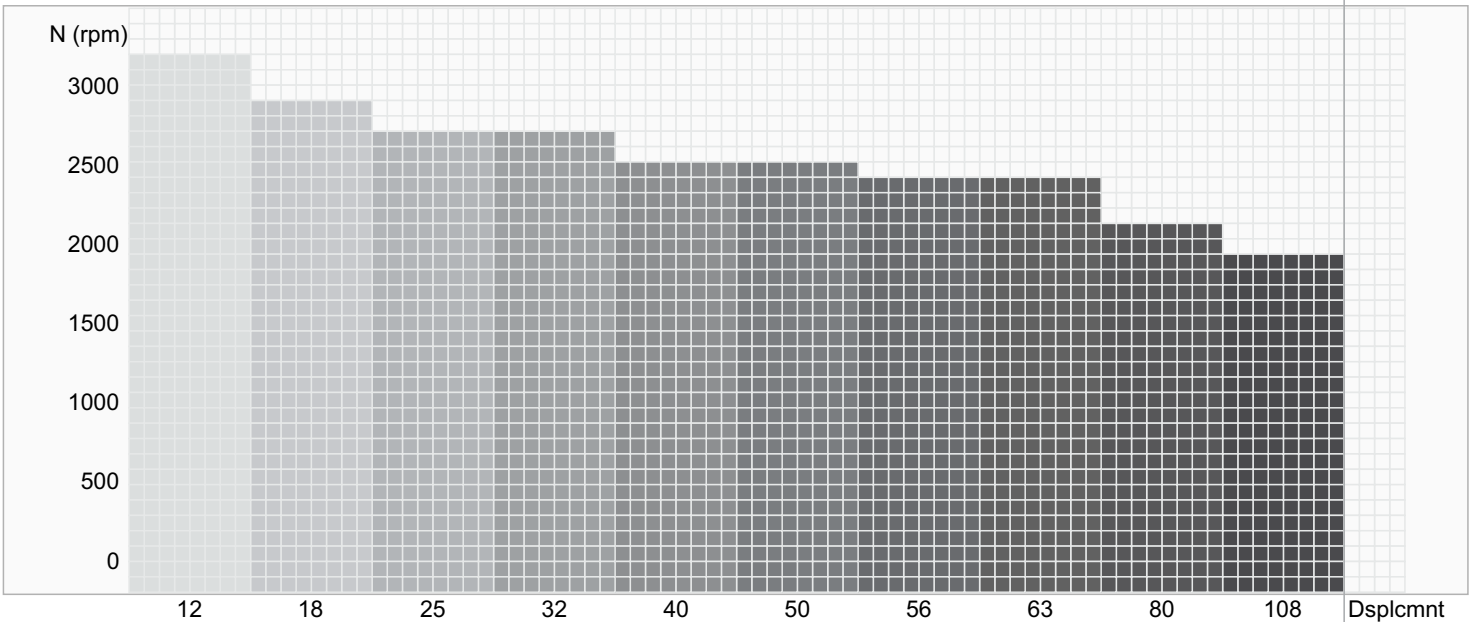

G2PA 12

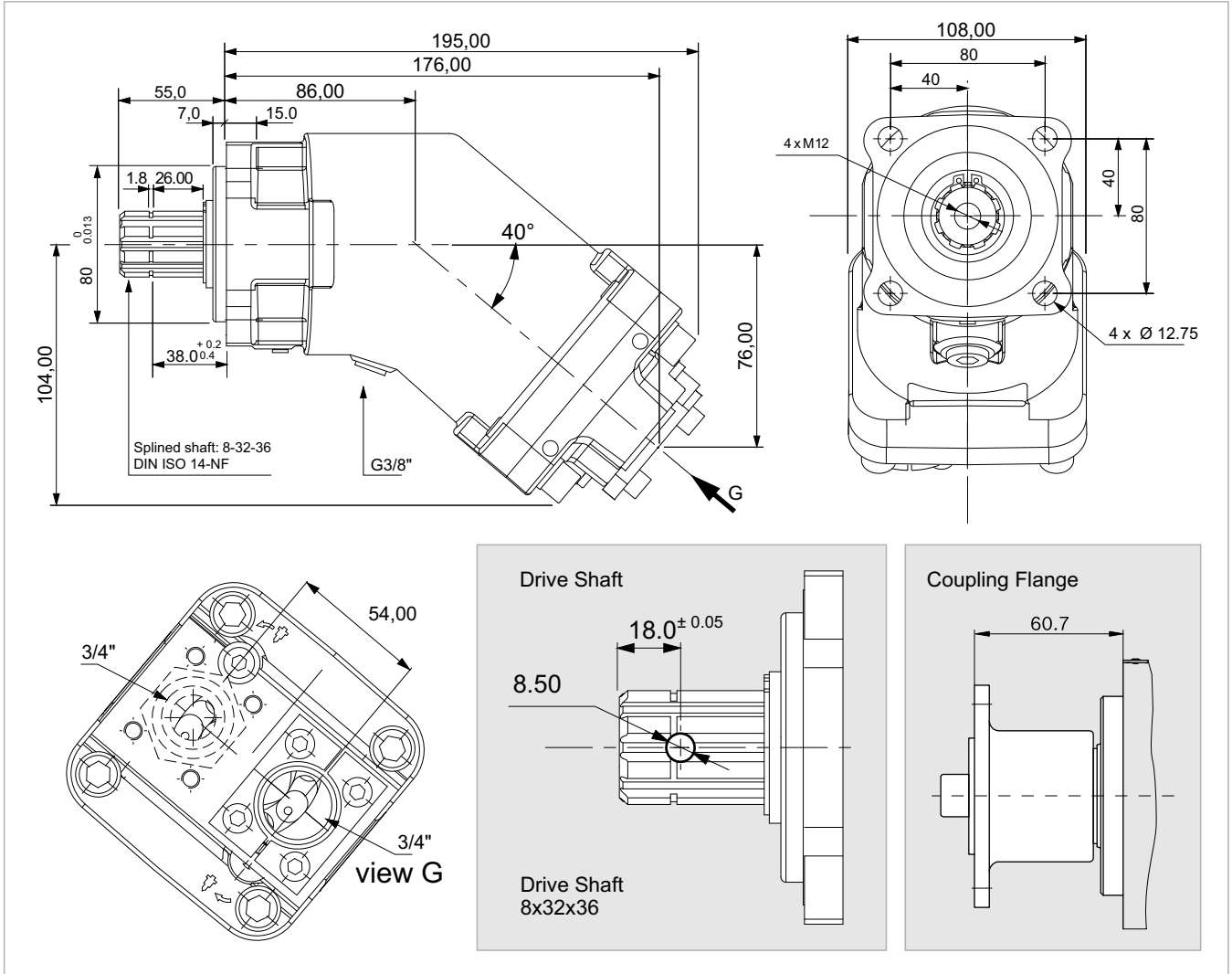

x 1000 rpm	12,00 cc
x 1500 rpm	18,00 cc
Max. Continuous Pump Speed	2300 rpm
Max. Limited Pump Speed	3100 rpm
Max. Continuous Pressure	350 bar
Max. Intermit. Peak Pressure	400 bar
Max. Torque at 350 bar	71 Nm
Weight without inlet fitting	9,00 kg
Weight with inlet fitting	9,40 kg
Torque without inlet fitting	8,70 N.m
Torque with inlet fitting	9,15 N.m
Rotation	CW-CCW
Fluid	Min.B.Hyd.Oil
Inlet & Outlet	3/4"

Flow, Speed, Pressure List of G2PA 12

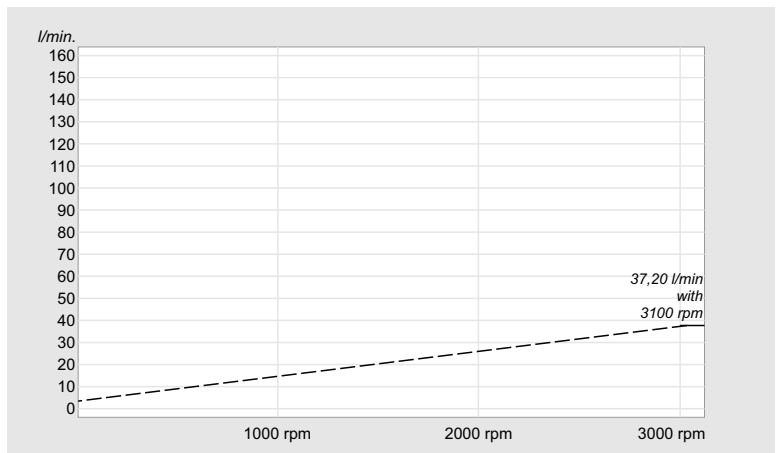

G2PA 18

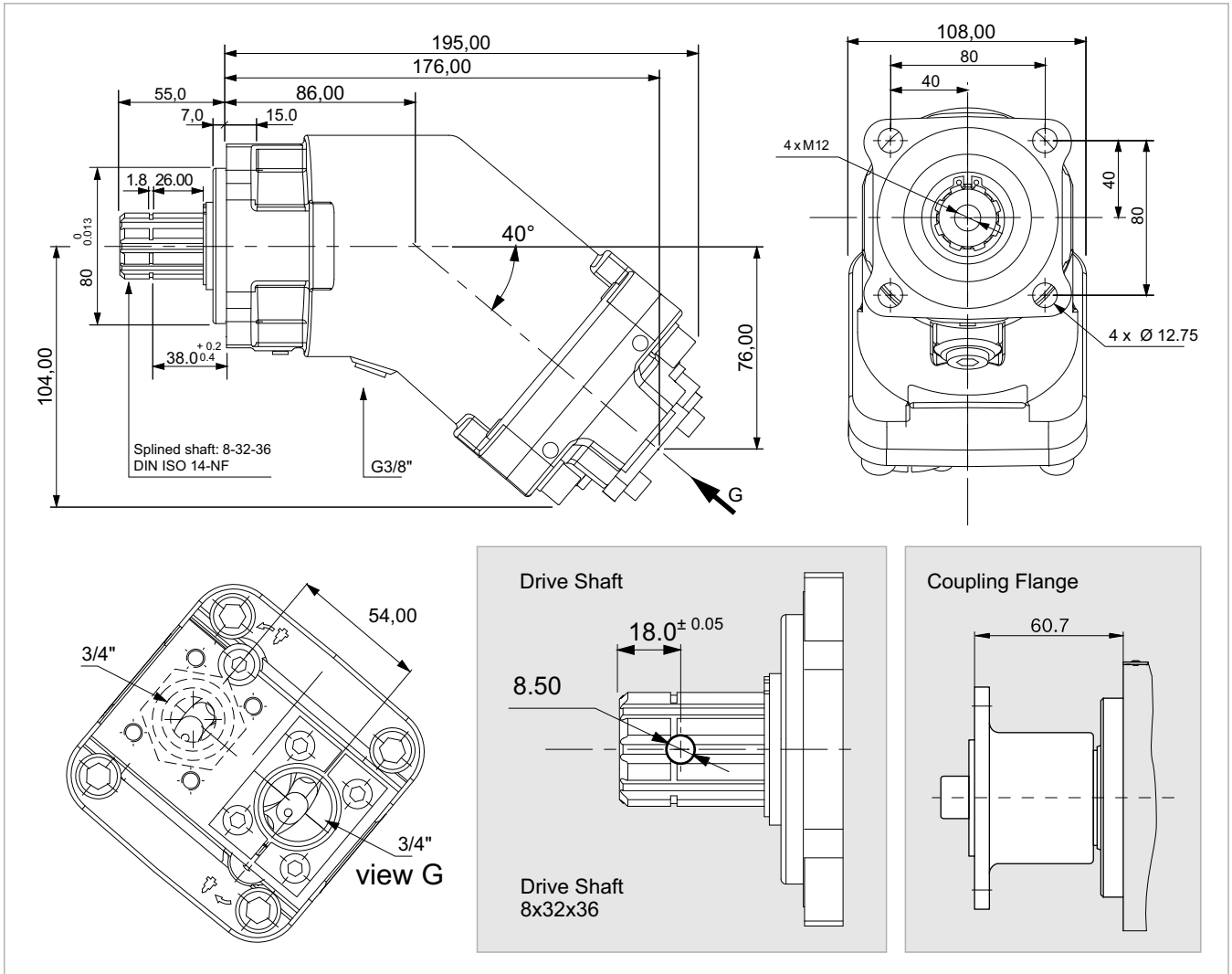

x 1000 rpm	18,00 cc
x 1500 rpm	27,00 cc
Max. Continuous Pump Speed	2300 rpm
Max. Limited Pump Speed	2900 rpm
Max. Continuous Pressure	350 bar
Max. Intermit. Peak Pressure	400 bar
Max. Torque at 350 bar	105 Nm
Weight without inlet fitting	9,00 kg
Weight with inlet fitting	9,40 kg
Torque without inlet fitting	8,75 N.m
Torque with inlet fitting	9,19 N.m
Rotation	CW-CCW
Fluid	Min.B.Hyd.Oil
Inlet & Outlet	3/4"

Flow, Speed, Pressure List of G2PA 18

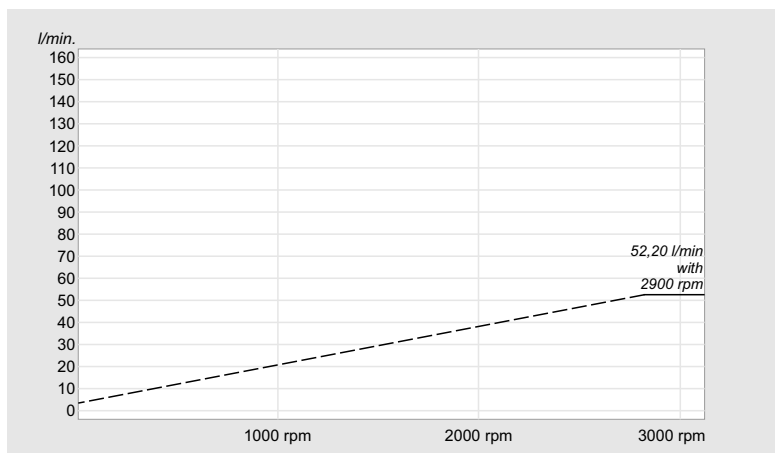

G2PA 25

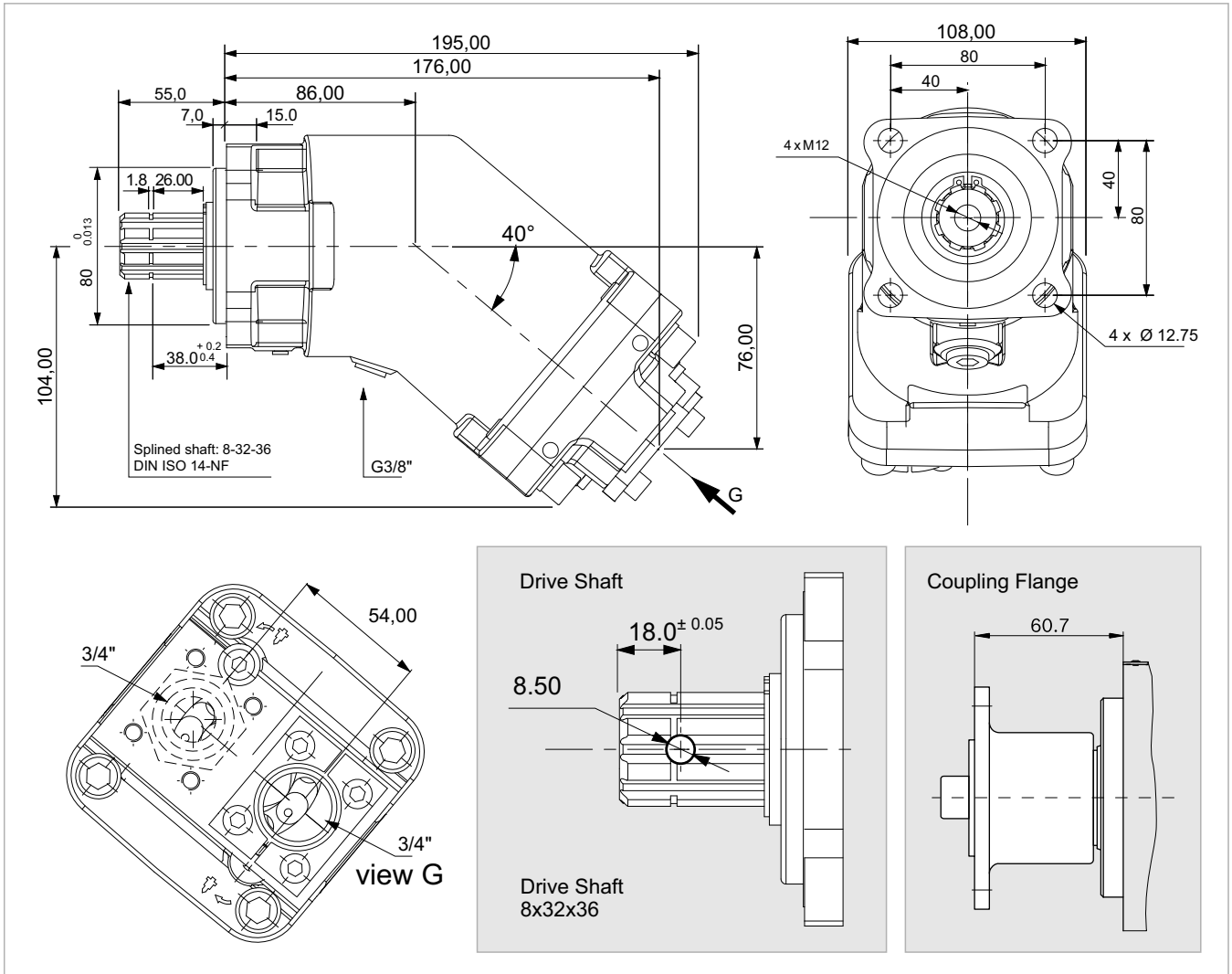

x 1000 rpm	25,00 cc
x 1500 rpm	37,50 cc
Max. Continuous Pump Speed	2300 rpm
Max. Limited Pump Speed	2700 rpm
Max. Continuous Pressure	350 bar
Max. Intermit. Peak Pressure	400 bar
Max. Torque at 350 bar	146 Nm
Weight without inlet fitting	9,50 kg
Weight with inlet fitting	9,90 kg
Torque without inlet fitting	8,82 N.m
Torque with inlet fitting	9,23 N.m
Rotation	CW-CCW
Fluid	Min.B.Hyd.Oil
Inlet & Outlet	3/4"

Flow, Speed, Pressure List of G2PA 25

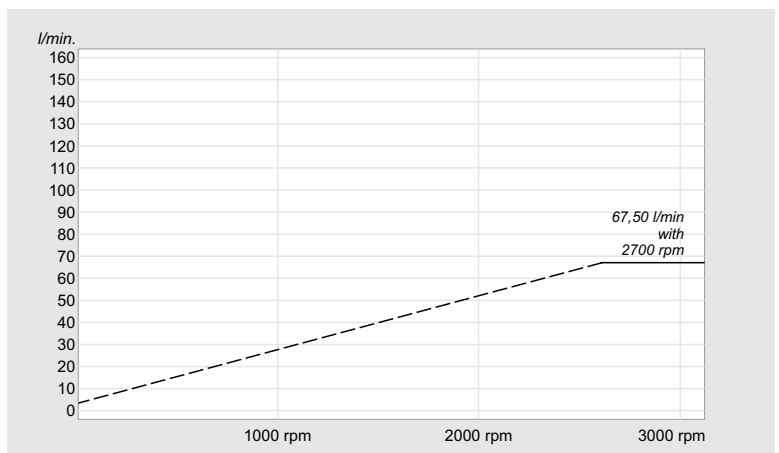

G2PA 32

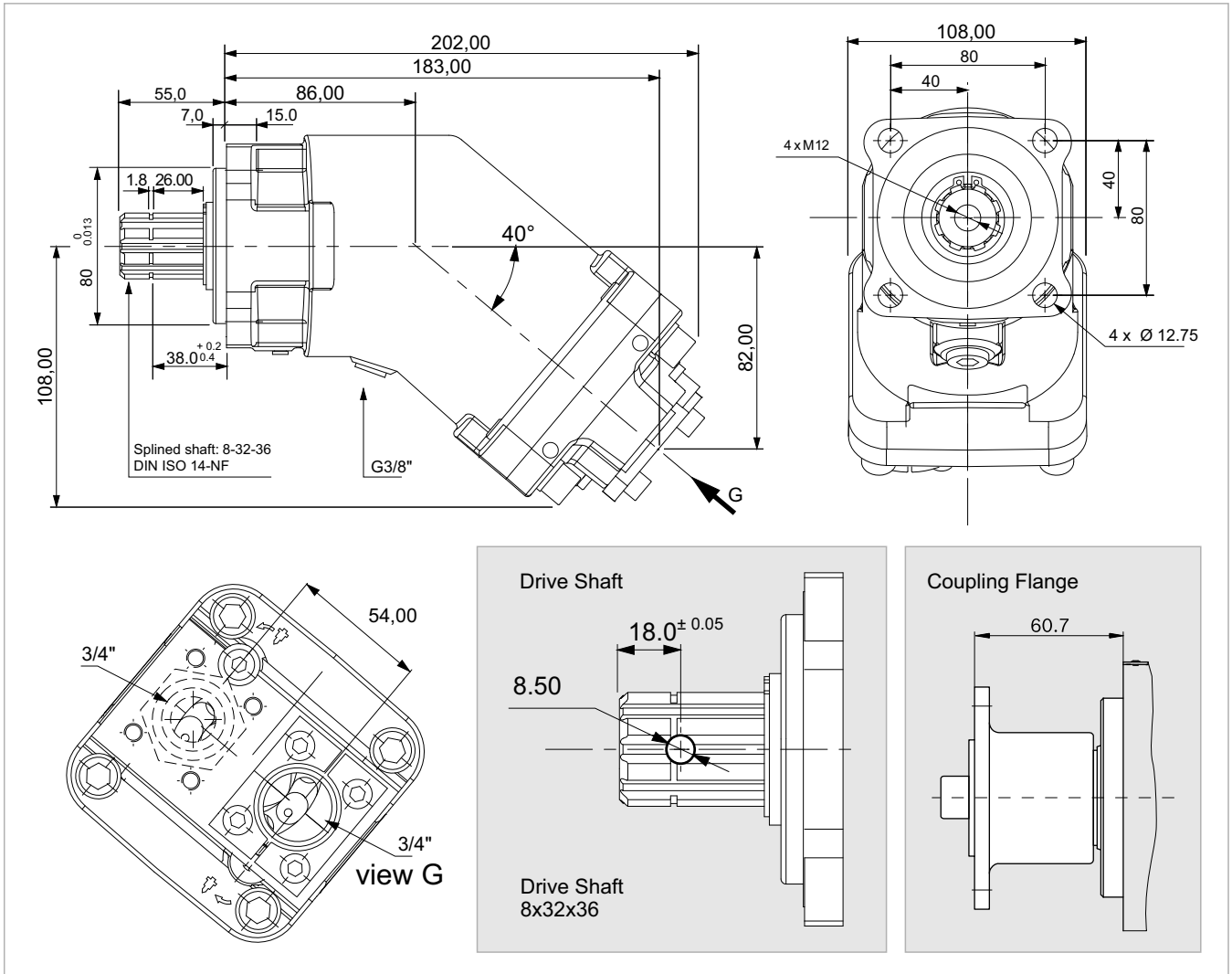

x 1000 rpm	32,00 cc
x 1500 rpm	48,00 cc
Max. Continuous Pump Speed	2250 rpm
Max. Limited Pump Speed	2700 rpm
Max. Continuous Pressure	350 bar
Max. Intermit. Peak Pressure	400 bar
Max. Torque at 350 bar	190 Nm
Weight without inlet fitting	10,50 kg
Weight with inlet fitting	10,90 kg
Torque without inlet fitting	11,00 N.m
Torque with inlet fitting	11,52 N.m
Rotation	CW-CCW
Fluid	Min.B.Hyd.Oil
Inlet & Outlet	3/4"

Flow, Speed, Pressure List of G2PA 32

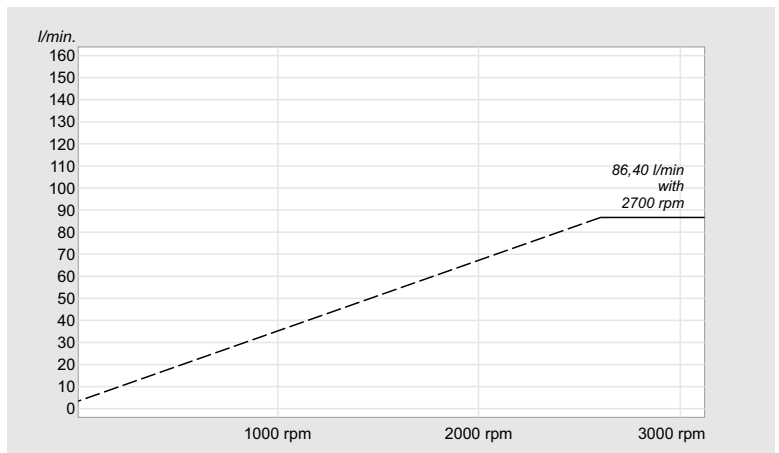

G2PA 40

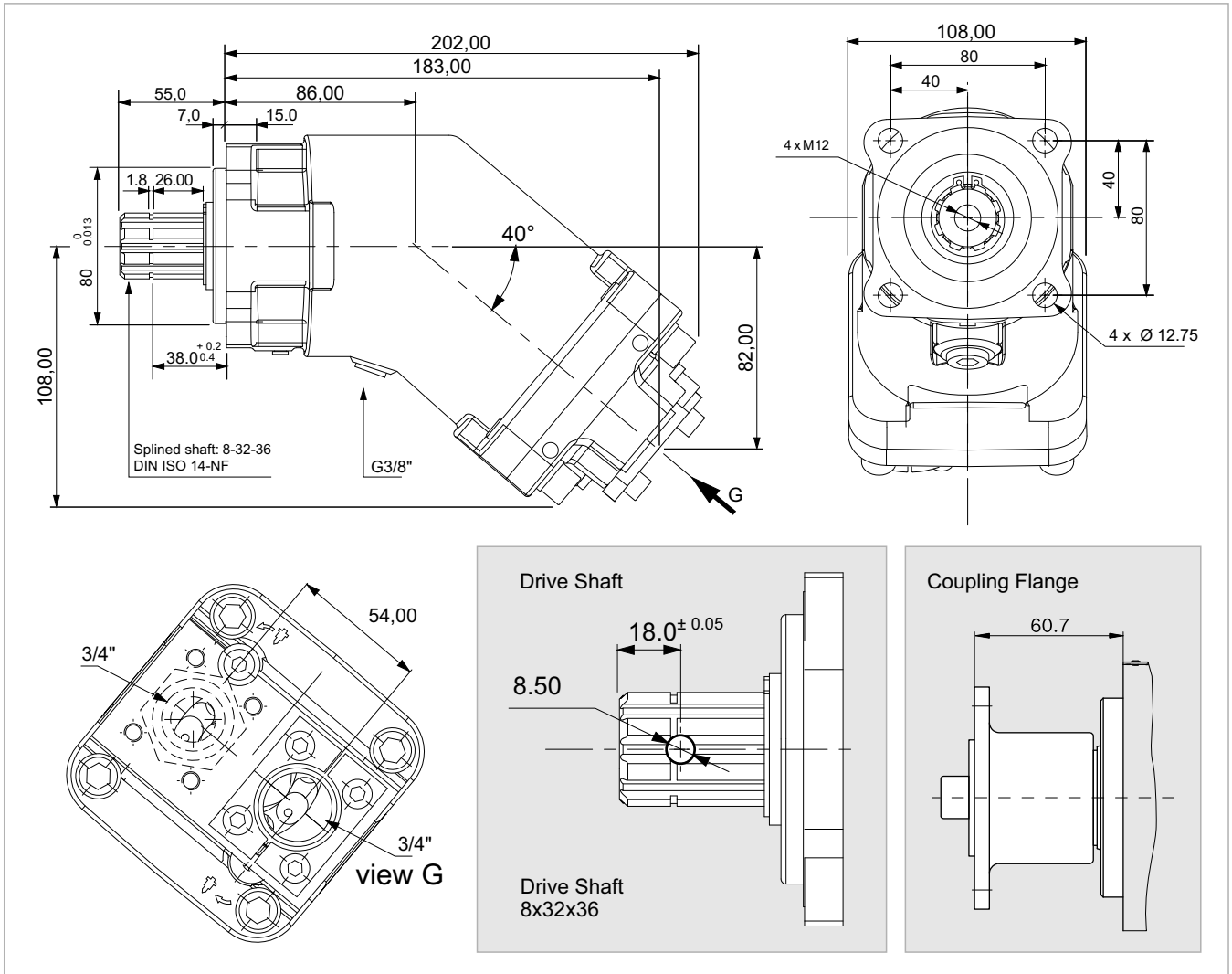

x 1000 rpm	40,20 cc
x 1500 rpm	60,30 cc
Max. Continuous Pump Speed	1900 rpm
Max. Limited Pump Speed	2500 rpm
Max. Continuous Pressure	350 bar
Max. Intermit. Peak Pressure	400 bar
Max. Torque at 350 bar	240 Nm
Weight without inlet fitting	10,50 kg
Weight with inlet fitting	10,90 kg
Torque without inlet fitting	11,12 N.m
Torque with inlet fitting	11,40 N.m
Rotation	CW-CCW
Fluid	Min.B.Hyd.Oil
Inlet & Outlet	3/4"

Flow, Speed, Pressure List of G2PA 40

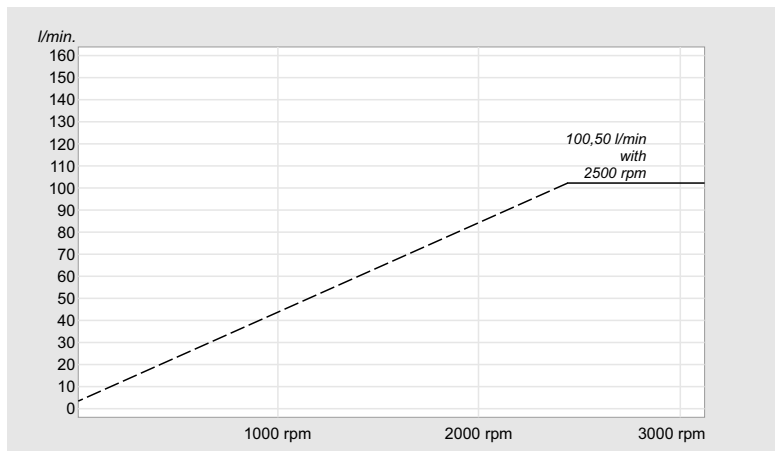

G2PA 50

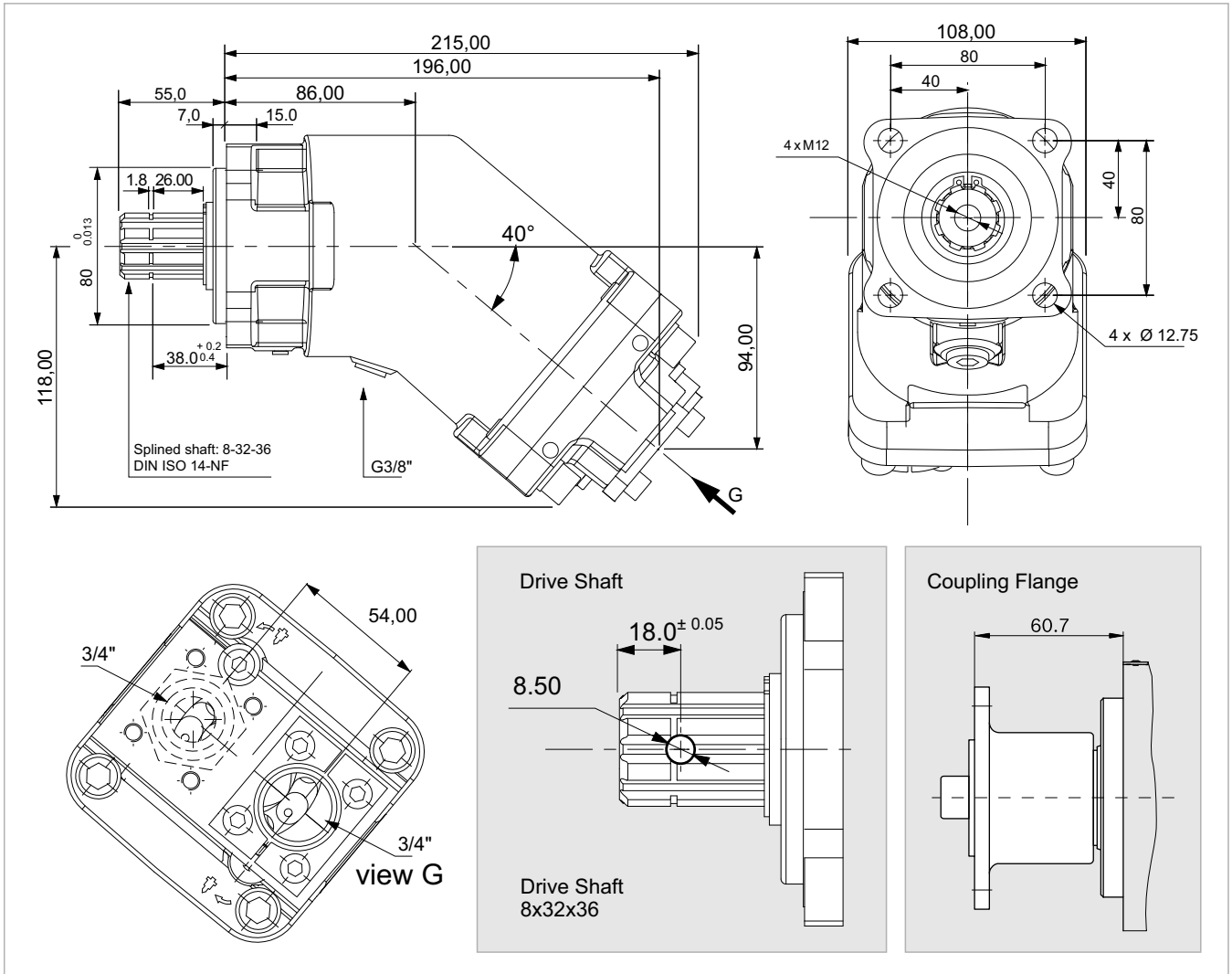

x 1000 rpm	50,00 cc
x 1500 rpm	75,00 cc
Max. Continuous Pump Speed	1900 rpm
Max. Limited Pump Speed	2500 rpm
Max. Continuous Pressure	350 bar
Max. Intermit. Peak Pressure	400 bar
Max. Torque at 350 bar	292 Nm
Weight without inlet fitting	11,00 kg
Weight with inlet fitting	11,40 kg
Torque without inlet fitting	11,72 N.m
Torque with inlet fitting	12,20 N.m
Rotation	CW-CCW
Fluid	Min.B.Hyd.Oil
Inlet & Outlet	3/4"

Flow, Speed, Pressure List of G2PA 50

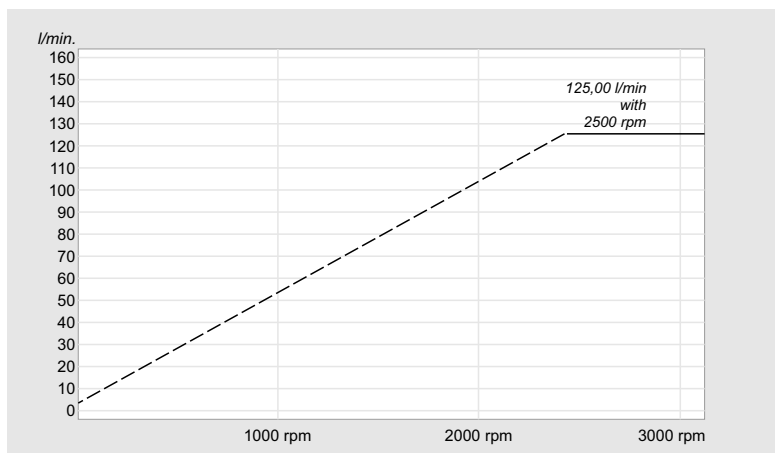

G2PA 56

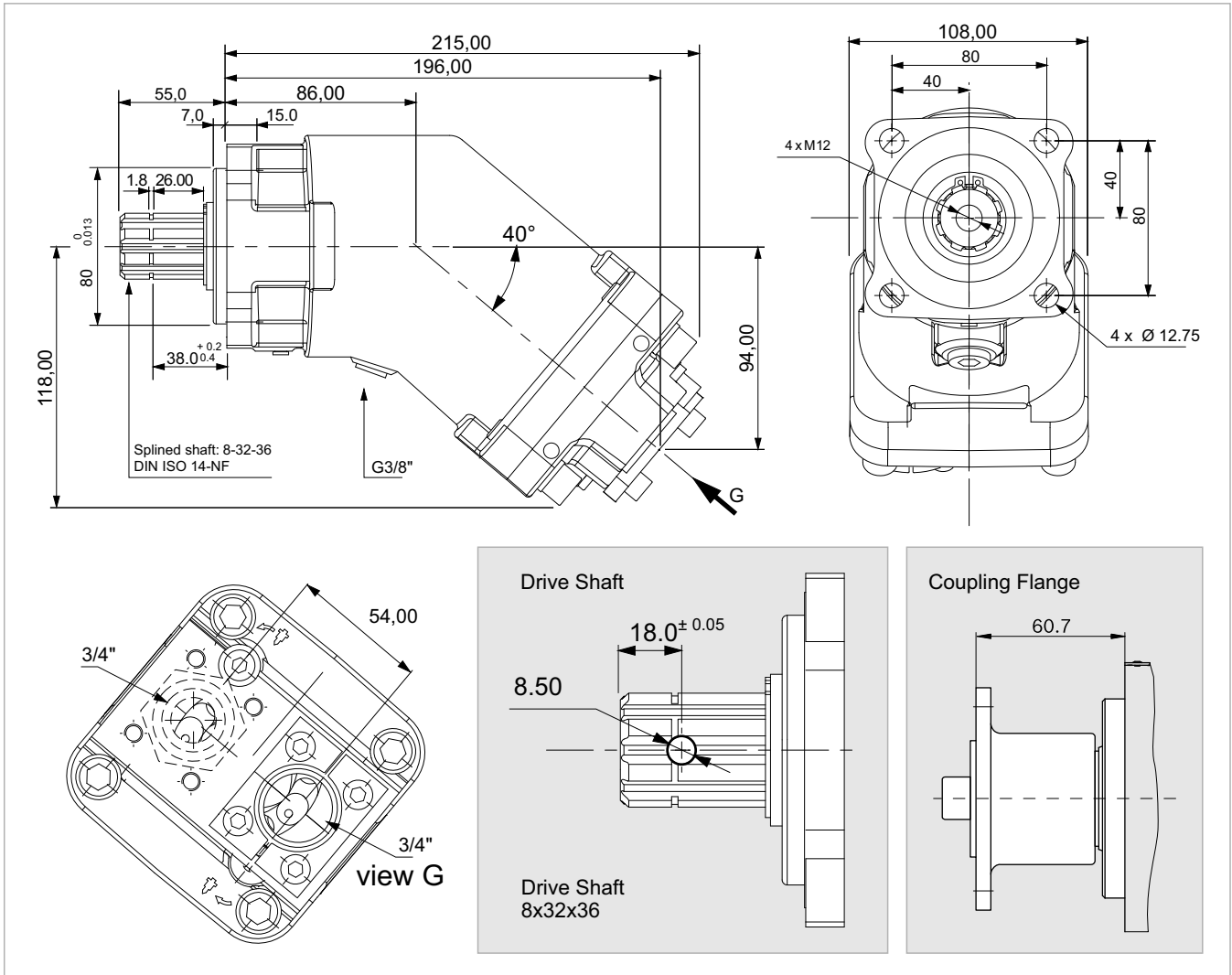

x 1000 rpm	56,40 cc
x 1500 rpm	84,60 cc
Max. Continuous Pump Speed	1900 rpm
Max. Limited Pump Speed	2300 rpm
Max. Continuous Pressure	350 bar
Max. Intermit. Peak Pressure	400 bar
Max. Torque at 350 bar	330 Nm
Weight without inlet fitting	11,50 kg
Weight with inlet fitting	11,90 kg
Torque without inlet fitting	11,79 N.m
Torque with inlet fitting	12,24 N.m
Rotation	CW-CCW
Fluid	Min.B.Hyd.Oil
Inlet & Outlet	3/4"

Flow, Speed, Pressure List of G2PA 56

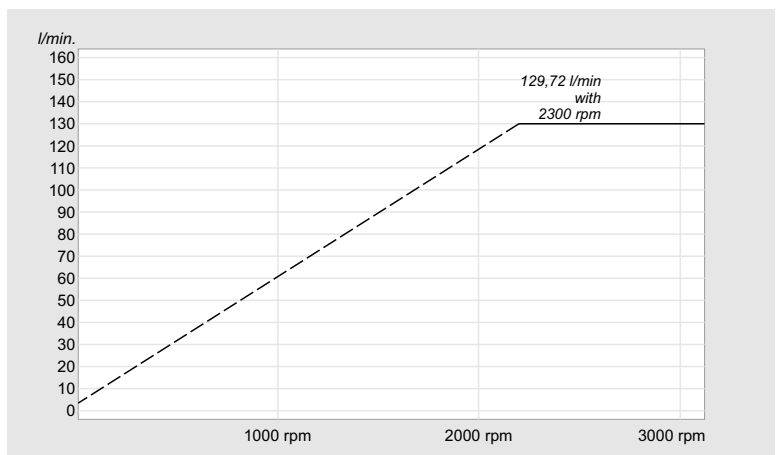

G2PA 63

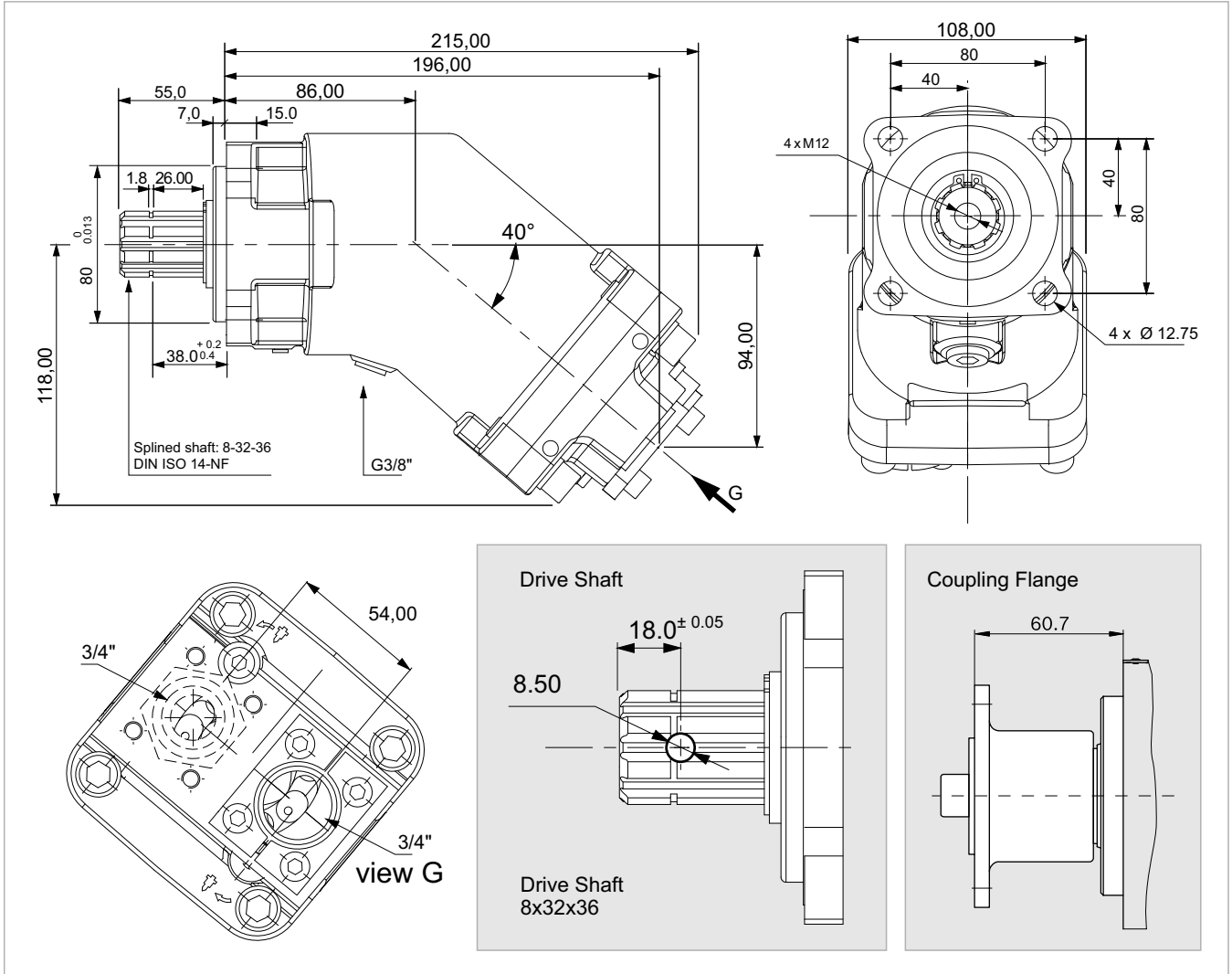

x 1000 rpm	63,00 cc
x 1500 rpm	94,50 cc
Max. Continuous Pump Speed	1900 rpm
Max. Limited Pump Speed	2300 rpm
Max. Continuous Pressure	350 bar
Max. Intermit. Peak Pressure	400 bar
Max. Torque at 350 bar	360 Nm
Weight without inlet fitting	11,50 kg
Weight with inlet fitting	11,90 kg
Torque without inlet fitting	11,82 N.m
Torque with inlet fitting	12,28 N.m
Rotation	CW-CCW
Fluid	Min.B.Hyd.Oil
Inlet & Outlet	3/4"

Flow, Speed, Pressure List of G2PA 63

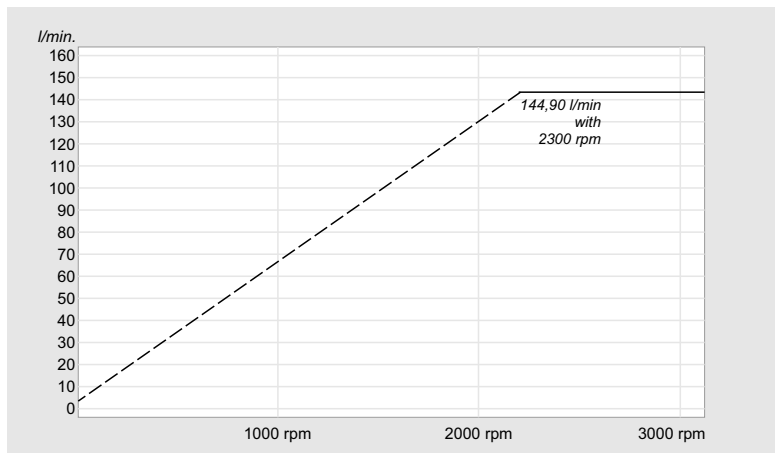

G2PA 80

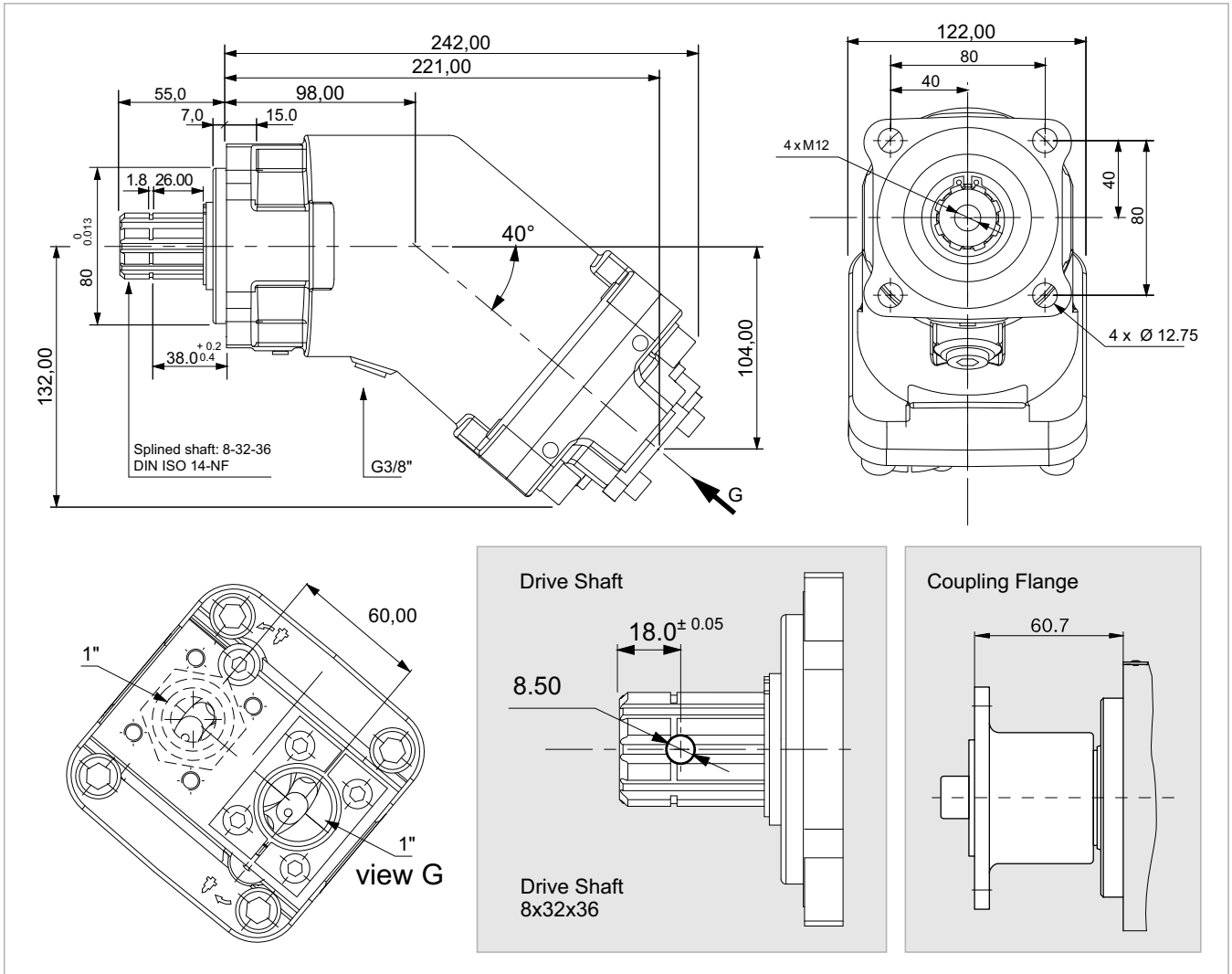

x 1000 rpm	80,00 cc
x 1500 rpm	120,00 cc
Max. Continuous Pump Speed	1700 rpm
Max. Limited Pump Speed	2100 rpm
Max. Continuous Pressure	350 bar
Max. Intermit. Peak Pressure	400 bar
Max. Torque at 350 bar	460 Nm
Weight without inlet fitting	15,00 kg
Weight with inlet fitting	15,40 kg
Torque without inlet fitting	17,80 N.m
Torque with inlet fitting	18,33 N.m
Rotation	CW-CCW
Fluid	Min.B.Hyd.Oil
Inlet & Outlet	1"

Flow, Speed, Pressure List of G2PA 80

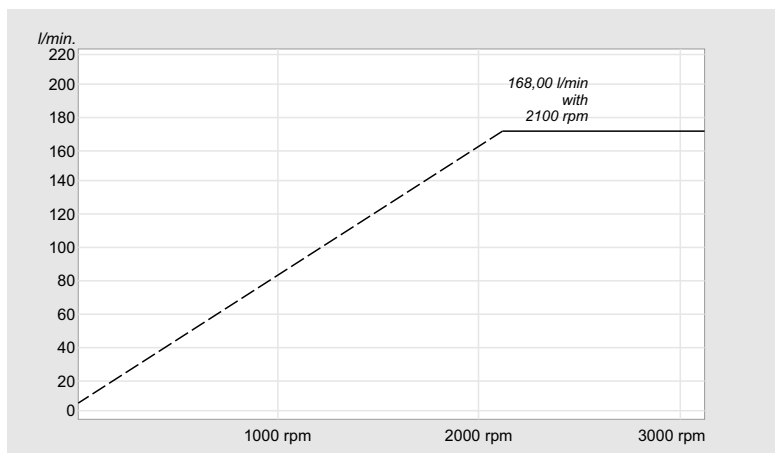

G2PA 108

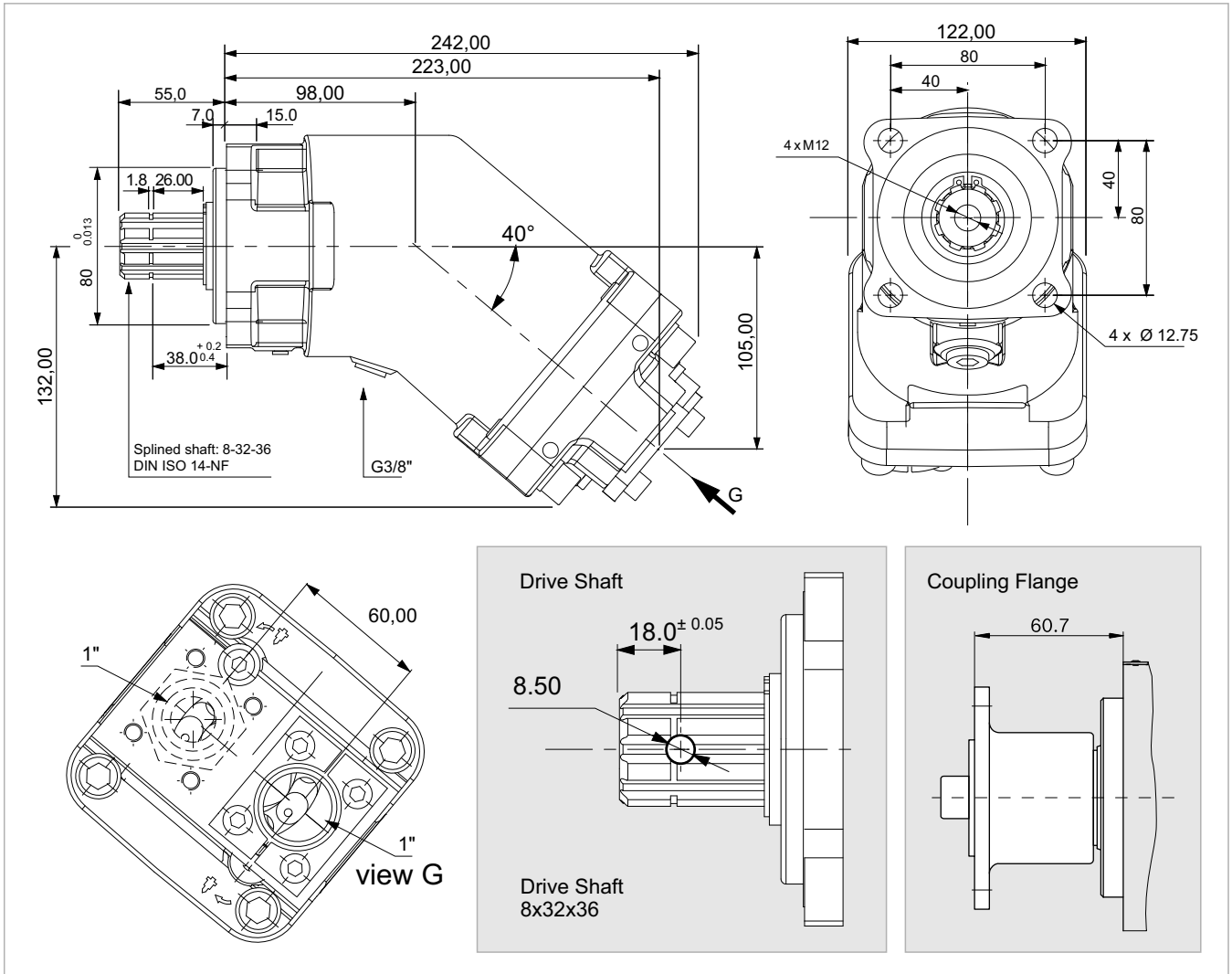

x 1000 rpm	108,40 cc
x 1500 rpm	162,60 cc
Max. Continuous Pump Speed	1700 rpm
Max. Limited Pump Speed	1900 rpm
Max. Continuous Pressure	350 bar
Max. Intermit. Peak Pressure	400 bar
Max. Torque at 350 bar	620 Nm
Weight without inlet fitting	15,50 kg
Weight with inlet fitting	15,90 kg
Torque without inlet fitting	17,92 N.m
Torque with inlet fitting	18,45 N.m
Rotation	CW-CCW
Fluid	Min.B.Hyd.Oil
Inlet & Outlet	1"

Flow, Speed, Pressure List of G2PA 108

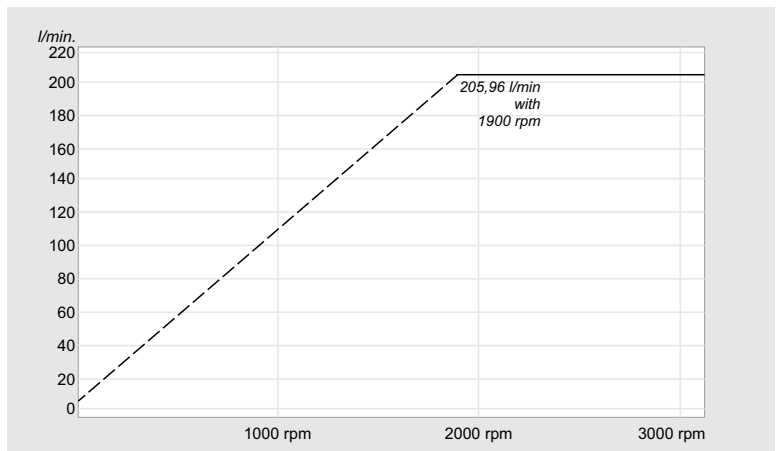

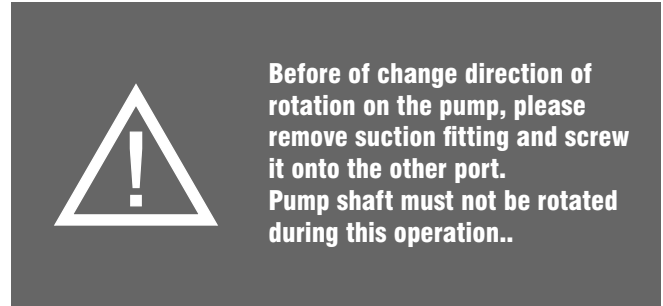
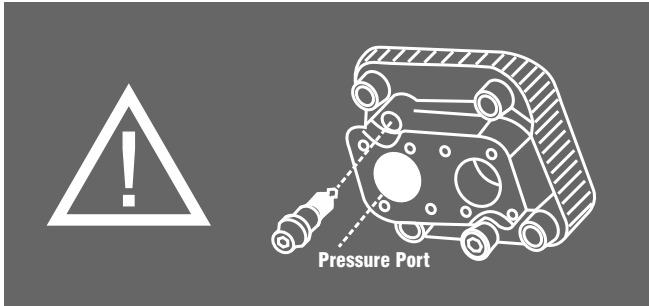

!! CHECK THE ROTATION FROM THE POWER TAKE OFF
!! THE ROTATION DIRECTION OF THE PUMP

Left Default delivered. Right Change rotation.

HOW TO CHANGE ROTATION OF THE G2PA PUMP;

- Remove the inlet fitting with split flange,
- Remove the setting screw,
- Remove the plug,
- Put the setting screw where the plug was,
- Put the plug where the setting screw was,
- Put seal on the inlet fitting, then the inlet fitting on the side where the plug is, and fix with the split flange, Tighten with the screws.

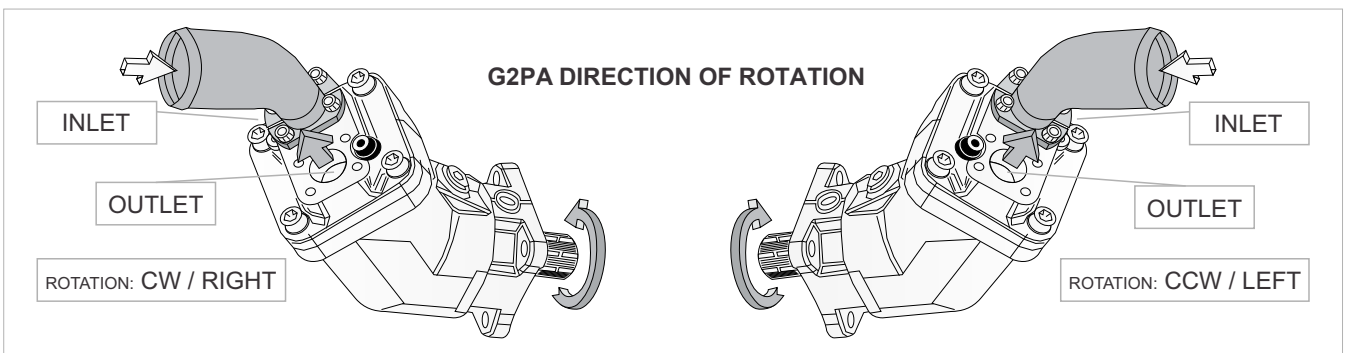
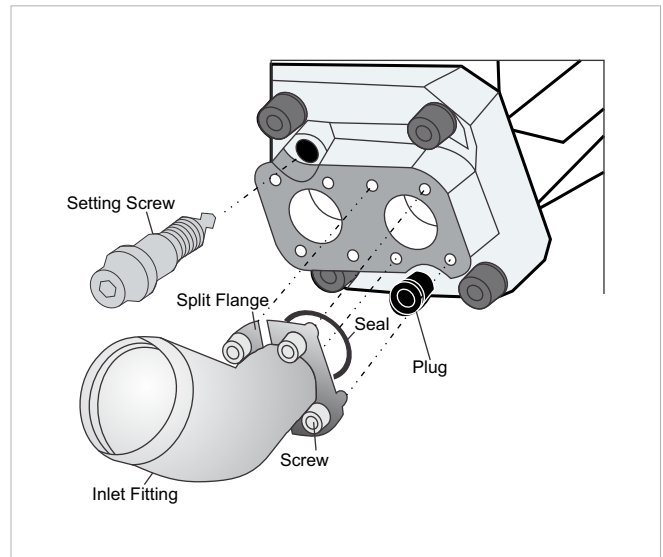

NOTE I
The Inlet Fitting is pre-assembled on delivery and must be tightened to the torque specified for the thread size before installation.

NOTE II
To change the direction of rotation of the G2PA Bent Axis Pump, you must change the pressure connection from to right port to the left port.

NOTE III
If the pump drive shaft moves while making the change, the G2PA Bent Axis Pump may be damaged. After unscrewing the pressure connection, do not turn the drive shaft of the pump!

FLUID

Please check the following recommendations: Mineral oil

Viscosity	20 to 40 cSt
Min. viscosity	5 cSt
Viscosity for correct operation	10 to 400 cSt
Recommended filtration	10µ absolute class 9 NAS 1638 class 6 SAE class 18/15 ISO
Max temp.	100° C



The G2PA pumps fitted with a rubber front seal.

INSTALLATION

G2PA pumps are direct mounting on the PTO.
Grease the splined shaft before installation. Do not tap the gear wheel/driver into position.

Remove any mounted screws on the pump.

The G2PA was delivered with protective covers and plastic/threaded plugs.
It should be removed before of install. Please check seals and surfaces. If sealing or other surfaces damaged please contact your responsible Service Partner.

Start up and run the pump at medium speed (800 to 1000 rpm at the PTO) until the oil flowing out of the pump. (There are no more air bubbles.)

OIL SUPPLY

Oil and supply line should be clean, and the supply line is airtight.

SUCTION LINE

Connect the suction line, tighten the suction connection bolts in diametric pairs.
Connect the pressure line.

REPAIR

We offers a comprehensive range of services for the repair of our Bent Axis Pumps.

Repairs to the G2PA Bent Axis Pump may only be performed by authorized, skilled and instructed personnel.

Only use original and pre-installed our G2PA spare parts from supplied to Manufacturer..

Tested and pre-installed G2PA pumps successful repair requiring only little time.

SPARE PARTS

The spare parts list and the G2PA pump order specific.

When ordering spare parts, quote the material and complete Ordering code number of the G2PA Bent Axis Pump as well as the right numbers of the spare parts.

RISK OF DAMAGE!

Do not touch the drive shaft of the G2PA Bent Axis Pump

Do not touch sensor, valves and fittings

Do not touch sealing surfaces.

DIMENSIONS & WEIGHTS

		12	18	25	32	40	50	56	63	80	108
- Without inlet fitting	kg	9,00	9,00	9,50	10,50	10,50	11,00	11,50	11,50	15,00	15,50
- With inlet fitting	kg	9,40	9,40	9,90	10,90	10,90	11,40	11,90	11,90	15,40	15,90

Address all questions regarding spare parts to your responsible Our Service Partner or the technical service department of the manufacture's plant / factory for the G2PA Bent Axis Pumps.

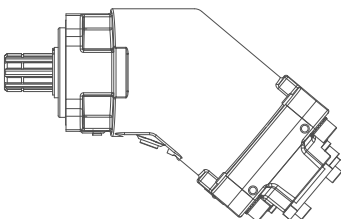

HYDROLINA HYDRAULICS, LTD.

Fevziçakmak mh. 10505 Sk.
No: 23/1 Karatay / KONYA

Phone : **+90 (551) 148 26 88**

Fax : +90 (551) 148 26 88

mail@hydrolina.com
order@hydrolina.com

DIN

DIN 5462 / ISO 14
8x32x35
8x32x36
DIN 6885



G2PA

G1PA

Piston Motors



G2PM

ISO

ISO 3019-2 (4 BOLTS)
DIN 5480 -W25,30,35,40,45
DIN 6885 -Ø20,25,30,35,40,45



G2P



G2M

SAE

SAE B2 C4 - SAE D
SAE J498b
SAE J 744



G2SE



G2EM

M2
Fixed Plug-in

DIN 5480 / ISO 3019-2
W30 - W35 - W40
M21 - M22 - M23



G2MS

DIN ISO 14
8x32x36

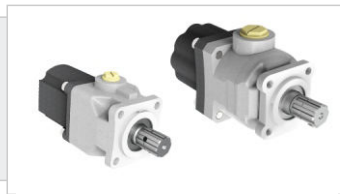

GPA

P2 Connection M8x125
Woodruff key 3x6,5 NF E
27-653 NF R 124-04
(2 BOLTS)



GPH

HYDROLINA HYDRAULICS, LTD.

Fevziçakmak mh. 10505 Sk.
No: 23/1 Karatay / KONYA

Phone : **+90 (551) 148 26 88**

Fax : +90 (551) 148 26 88

mail@hydrolina.com
order@hydrolina.com

G2PA

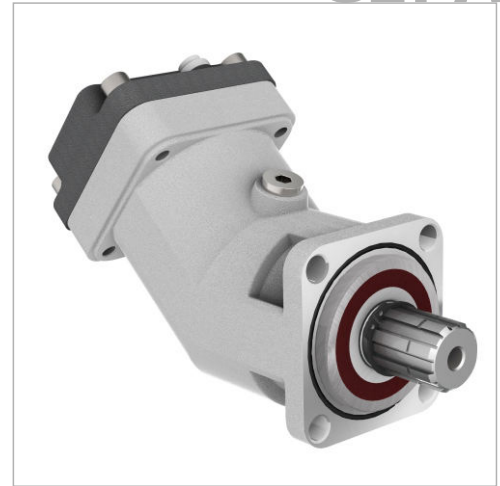

 *Pumps, Motors, Hydraulic Components...*



HOME CORPORATE PRODUCT LINE PUMPS MOTORS INDUSTRIAL & MOBILE HYDRAULIC LOCATIONS ENVIRONMENT CATALOGS WorldWide

G2PA

Bent Axis Piston Pumps

- Compact Design,
- Economical Conception,
- High Rotating Speeds,
- High Output Pressure.

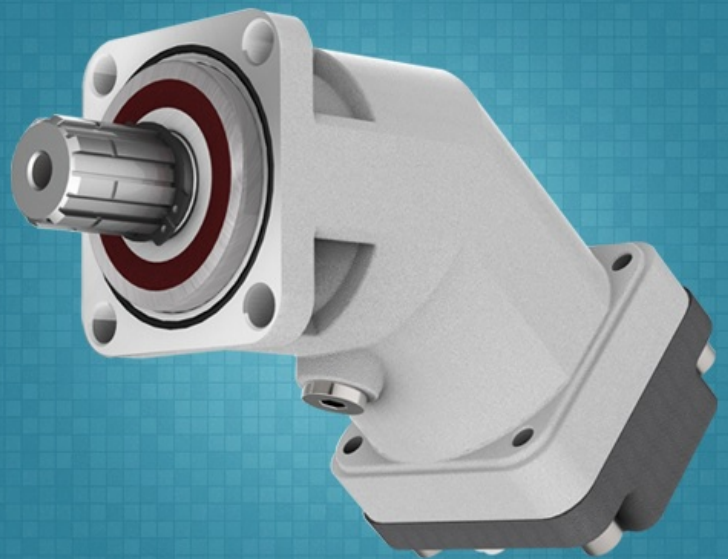

hydrolina.com